

brother



**HIGH-SPEED LOCK STITCH MACHINE
SCHNELLNÄHMASCHINEN FÜR STEPPSTICH
MACHINE A POINT D'ARRET A GRANDE VITESSE
DOBLE PESPUNTEADORA DE ALTA VELOCIDAD**

DB2-B714



**PARTS BOOK
TEILEKATALOG
LIVRE DES PIECES
LIBRO DE REFERENCIA DE PIEZAS**

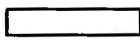

Notes for using this parts book

1. If the symbol  is found in the "Parts No." column or the "Assembly No." column, refer to the different parts list on page 14.
2. The symbol  in the "Parts No." column indicates that the parts is not available for supply. If, however, there is a number in the "Assembly No." column, the parts can be ordered as an assembly. Please, therefore, order by using the Assembly No.
3. This book was prepared based on information available in May, 1984.
4. Parts are subject to changes in design without prior notice.

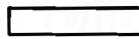
Anmerkungen zum Gebrauch dieses Stücklistebuches

1. Dieses Zeichen  in der Spalte "Parts No. (Teilnummer)" oder "Assembly No. (Gerätesatznummer)" verweist auf die Gesonderte Stückliste auf Seite 14.
2. Dieses Zeichen  in der Spalte "Teilnummer" bedeutet, daß dieser Teil nicht lieferbar ist. Wenn jedoch in der Spalte "Gerätesatznummer" eine Nummer steht, kann dieser Teil als ein Geräteteilsatz bestellt werden. Bestellen Sie daher bitte mit dieser Gerätesatznummer.
3. Dieses Buch basiert auf den Informationen vom Mai, 1984.
4. Modelländerungen sind vorbehalten.

CONTENTS

A.	Machine body	1
B.	Threading mechanism	2
C.	Needle bar and thread take-up mechanism	3
D.	Rotary hook mechanism	4
E.	Feed mechanism (1)	5
E.	Feed mechanism (2)	6
F.	Presser foot mechanism	7
G.	Knee lifter mechanism	8
H.	Lubrication	9
J.	Bobbin winder mechanism	10
Z.	Accessories (1)	11
Z.	Accessories (2)	12
a.	Option parts	13
	DIFFERENT PARTS LIST	14
	GAUGE PARTS LIST	15
	INDEX	19

INHAITSVERZEICHNIS

A.	Maschinengehäuse	1
B.	Fadenführungsvorrichtung	2
C.	Nadelstange und Fadennabnahmevorrichtung	3
D.	Greifervorrichtung	4
E.	Transportvorrichtung (1)	5
E.	Transportvorrichtung (2)	6
F.	Stoffdrückerfuß	7
G.	Kniehebel	8
H.	Schmierung	9
J.	Spuler	10
Z.	Zubehör (1)	11
Z.	Zubehör (2)	12
a.	Sonderzubehör	13
	ZUBEHORLISTE	14
	LEHREN LISTE	15
	VERZEICHNIS	19

Notes sur l'utilisation de ce manuel de pièces détachées



1. Si le symbole  se trouve dans la colonne "Parts No. (N° de pièce)" ou dans la colonne "Assembly No. (N° jeu de pces)", veuillez vous référer à la liste de pièces annexe page 14.
2. Le symbole  dans la colonne "N" de pièce" signifie que la pièce ne peut être fournie. Si, dans la colonne "N" jeu de pces", il y a un numéro de nomenclature, la pièce peut être commandée comme faisant partie d'un jeu de pièces. Donc, pour toute commande, veuillez spécifier le N° de jeu de pièces.
3. Ce manuel a été fait d'après les renseignements valables au mois de Mai 1984.
4. Les pièces peuvent être sujettes à des modifications sans préavis.

TABLE DES MATIERES

A.	Corps de la machine	1
B.	Mécanisme de l'enfilage	2
C.	Mécanisme de la barre à aiguille et releveur de fil	3
D.	Mécanisme du crochet rotatif	4
E.	Mécanisme de l'entraînement (1)	5
E.	Mécanisme de l'entraînement (2)	6
F.	Mécanisme du pied presseur	7
G.	Mécanisme de genouillère	8
H.	Lubrification	9
J.	Mécanisme du bobineur	10
Z.	Accessoires (1)	11
Z.	Accessoires (2)	12
a.	Pièces en option	13
	LISTE DES PIECES ACCESSOIRES	14
	LISTE DES PIECES DECARTEMENT	15
	INDEX	19

Notas para usar este Libro de Piezas

1. De haber un símbolo  junto al "Parts No. (Número de Pieza)" o en la columna del "Assembly No. (Número de Juego)", habrá que mirar la lista de piezas separada de la página 14.
2. El símbolo , que se encuentra en la columna del "Número de Pieza", quiere decir que no se dispone de dicha pieza sola. Cuando, empero, hay un número en la columna del "Número de Juego", se podrá ordenar la pieza con todo el juego. Por lo tanto, será mejor hacer el pedido recurriendo al número del juego respectivo.
3. Este libro ha sido compilado basándose en los datos de que se disponía en Mayo 1984.
4. Las piezas quedan sujetas a cambios de diseño sin aviso previo.

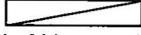
INDICA

A.	Cuerpo de la máquina	1
B.	Mecanismo de la enhebrado	2
C.	Mecanismo de la barra de aguja y tirahilos	3
D.	Mecanismo del cangrejo	4
E.	Mecanismo de la alimentación (1)	5
E.	Mecanismo de la alimentación (2)	6
F.	Mecanismo del prensa telas	7
G.	Mecanismo de levantador de rodilla	8
H.	Lubricación	9
J.	Mecanismo del de vanador la canilla	10
Z.	Accesorios (1)	11
Z.	Accesorios (2)	12
a.	Piezas opcióna	13
	LISTA DE PIEZAS ACCESORIAS	14
	LISTA DE PIEZAS CALIBRADORAS	15
	INDICE	19

A. Machine body / Maschinengehäuse
 Corps de la machine / Cuerpo de la máquina

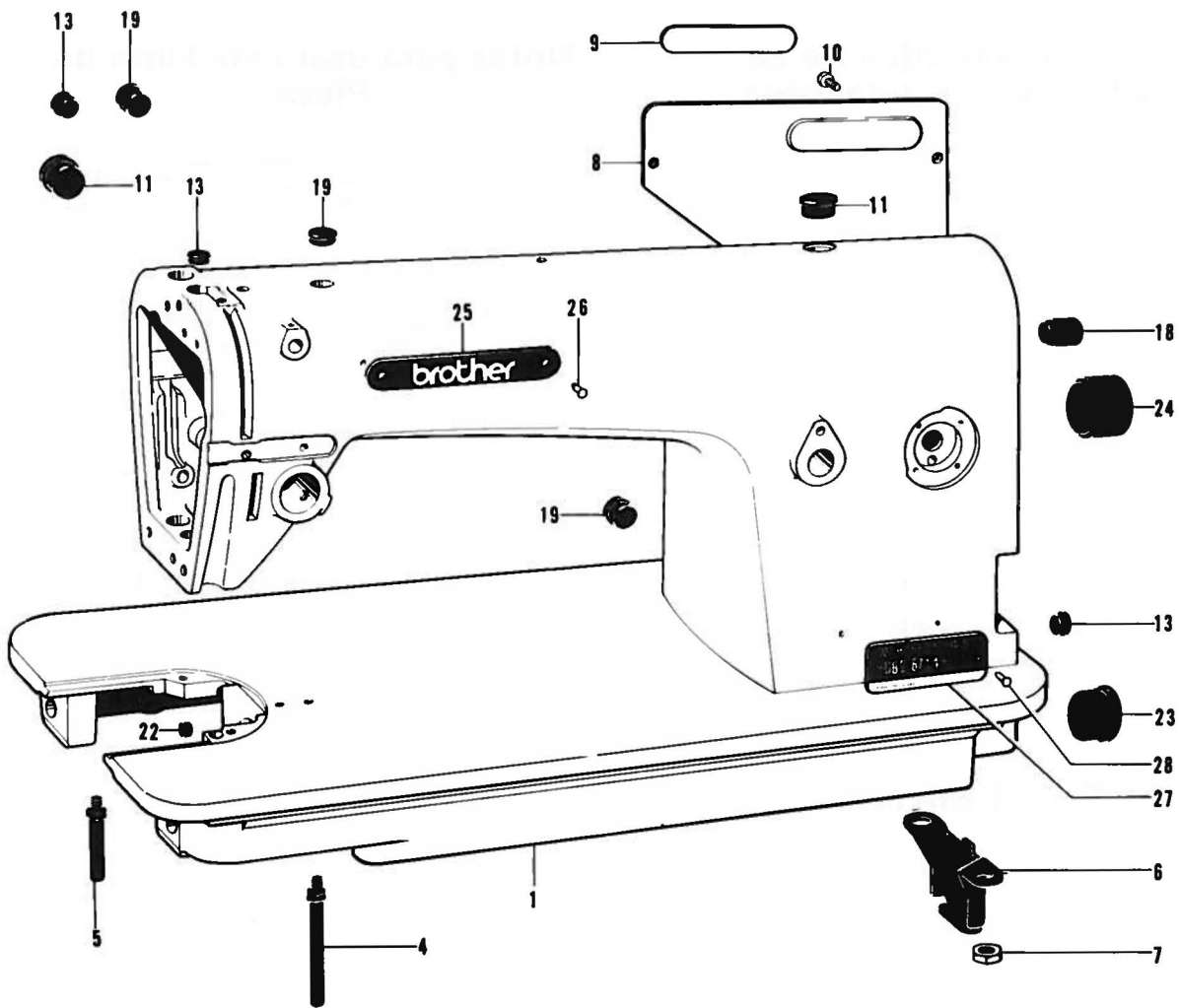

Ref. No.	Name of Parts	Q'ty	Parts No.	Assembly No.	Ref. No.	Name of Parts	Q'ty	Parts No.	Assembly No.
1	Arm Bed	1			18	Oil Cap	1	104832-001	
4	Bed Leg A	1	104829-101		19	Oil Cap	3	104821-001	
5	Bed Leg B	1	104830-101		22	Oil Cap	1	104833-001	
6	Pump Cover	1	145454-001		23	Oil Cap	1	108520-001	
7	Nut 7.14	2	100090-004		24	Oil Cap	1	104451-001	
8	Rear Cover	1	145455-002		25	Name Plate	1		
9	Name Plate	1			26	Pin	2		
10	Screw 357-40 x 8	5	062670-812		27	Model Plate	1		
11	Oil Cap	2	104449-001		28	Pin	2		
13	Oil Cap	3	104450-001						

B. Threading mechanism / FadenführungsVorrichtung
 Mécanisme de l'enfilage / Mecanismo de la enhebrado

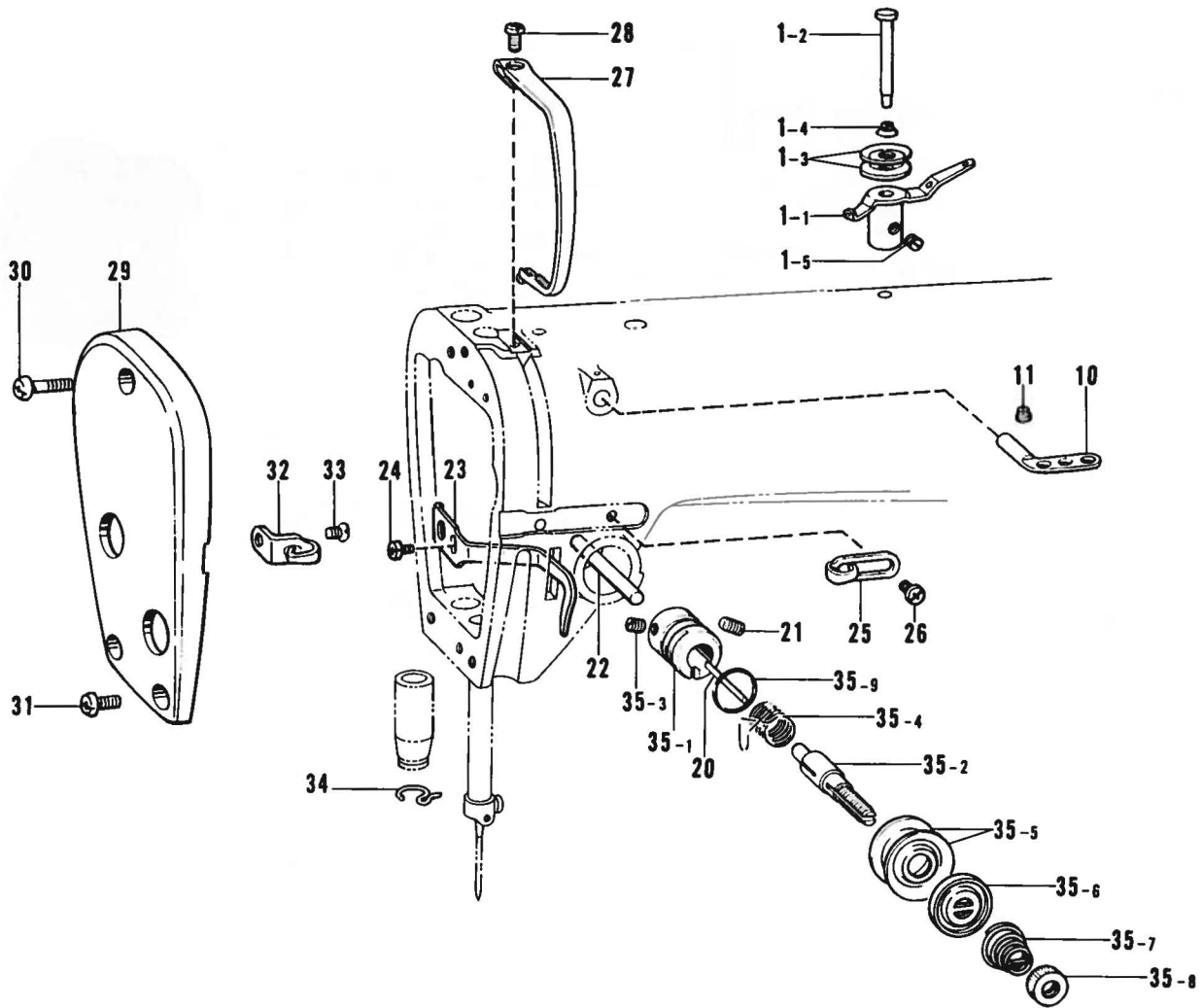

Ref. No.	Name of Parts	Q'ty	Parts No.	Assembly No.	Ref. No.	Name of Parts	Q'ty	Parts No.	Assembly No.
1- 1	Pre-Tension	1		B-1 Pre-Tension Assembly 144502-001	29	Face Plate	1	145523-102	
1- 2	Pre-Tension Stud	1			30	Screw 357-40 x 20	1	062672-012	
1- 3	Thread Guide Disc	2	144504-001		31	Screw 357-40 x 10	2	062671-012	
1- 4	Spring	1	144505-000		32	Face Plate Thread Guide	1	111476-001	
1- 5	Screw 4.37	1	102716-004		33	Screw 3.57	1	108960-002	
10	Thread Retainer	1	114931-001	34	Thread Guide Under	1	100573-001		
11	Screw 4.37	1	151602-002	35- 1	Upper Tension Regulator Bracket	1	144741-001	B-35 Tension Regulator Assembly	
20	Tension Release Pin	1	100400-000	35- 2	Tension Stud	1			
21	Screw 5.95	1	103950-003	35- 3	Screw 3.57	1	100402-004		
22	Pin	1	145526-001	35- 4	Thread Take-up Spring	1	145519-001		
23	Presser Bar Bracket Thread Guide	1	111469-101	35- 5	Tension Disc	2	145446-001		
24	Screw 437-40 x 7	1	062680-712	35- 6	Tension Disc Washer	1	159805-001		
25	Thread Guide R	1	145522-001	35- 7	Tension Spring	1			
26	Screw 357-40 x 6	1	062670-612	35- 8	Tension Control Nut	1	100136-001		
27	Thread Take-up Cover	1	140885-005	35- 9	Packing	1	114294-001		
28	Screw 437-40 x 7	1	062680-712						

C. Needle bar and thread take-up mechanism / Nadelstange und Fadenabnahmevorrichtung
 Mécanisme de la barre à aiguille et releveur de fil / Mecanismo de la barra de aguja y tirahilos

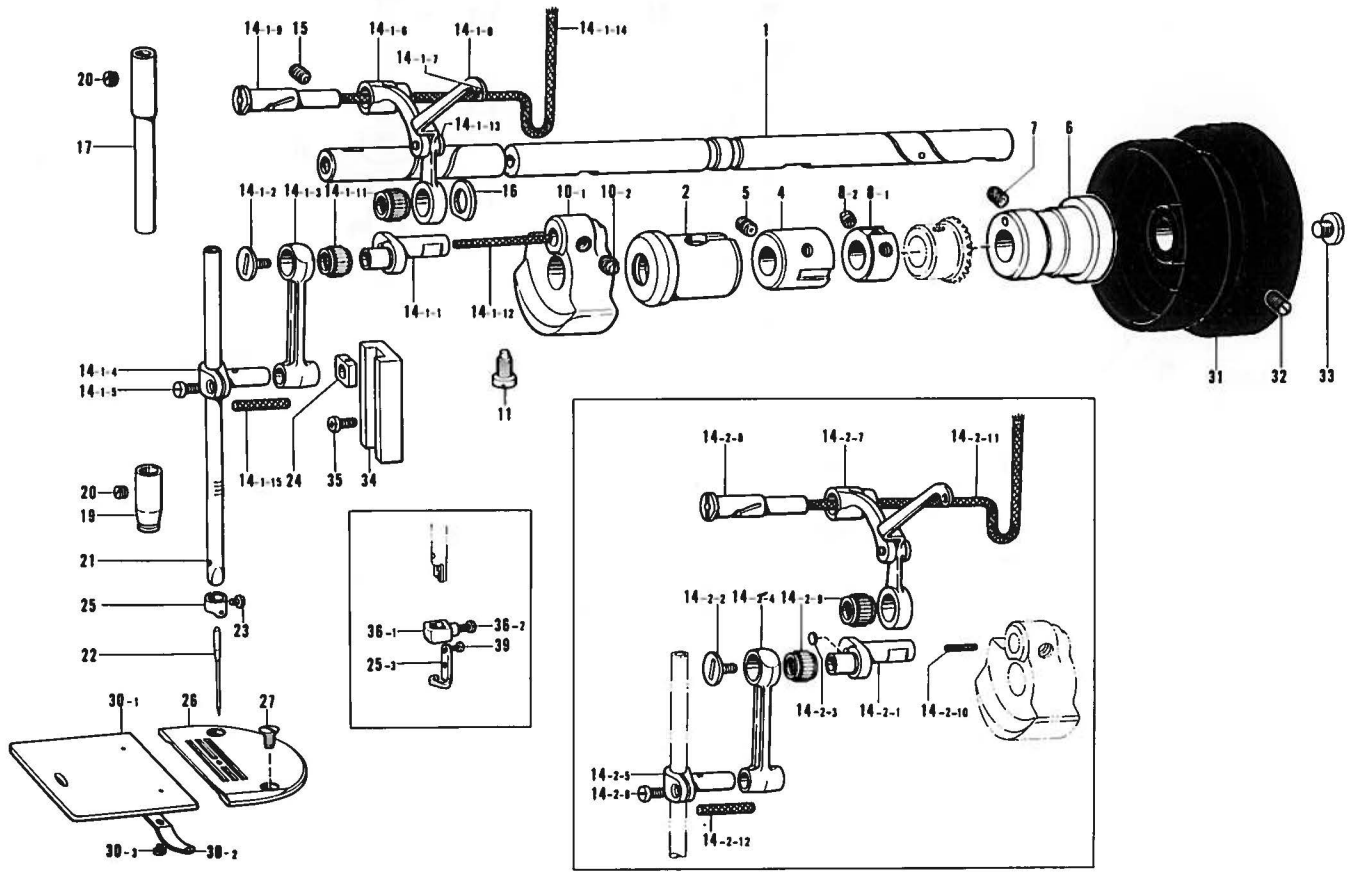

Ref. No.	Name of Parts	Q'ty	Parts No.	Assembly No.	Ref. No.	Name of Parts	Q'ty	Parts No.	Assembly No.	
1	Upper Shaft	1	147511-001		14- 2- 7	Thread Take-up Supporter Assembly	1		C-14-2 Thread Take-up Lever Assembly	
2	Upper Shaft Bushing Left	1	145459-101		14- 2- 8	Stud	1			
4	Upper Shaft Bushing Intermediate	1	140726-000		14- 2- 9	Needle Bearing	2			
5	Screw 5.95 x 6	1	013760-610		14- 2-10	Felt	1	145624-000		
6	Upper Shaft Bushing Right	1	145461-101		14- 2-11	Wick	1			
7	Screw 5.95 x 6	1	013760-610		14- 2-12	Wick 4 x 4	1	158727-001		
8- 1	Collar	1		C-8 Collar Assembly 181916-001	15	Screw 6.35 x 10	1	013781-012		
8- 2	Screw 6.35	2	100251-001		16	Washer	1	110367-001		
10- 1	Counter Weight	1		C-10 Counter Weight Assembly	17	Needle Bar Bushing Upper	1			
10- 2	Screw 6.35	2	100251-001		19	Needle Bar Bushing Lower	1			
11	Screw 7.14	1	104464-001		20	Screw 5.95	2	100260-001		
14- 1- 1	Needle Bar Crank	1		C-14-1 Thread Take-up Lever Assembly	21	Needle Bar	1			
14- 1- 2	Screw 3.57 L	1	145465-001			22	Needle	1		
14- 1- 3	Needle Bar Crank Rod	1				23	Screw 3.18	1		
14- 1- 4	Needle Bar Clamp	1				24	Needle Bar Guide Slide Block	1	102630-001	
14- 1- 5	Screw 357-40 x 8	1	062670-812			25	Needle Bar Thread Guide	1		
14- 1- 6	Thread Take-up Supporter Assembly	1				25- 3	Needle Bar Thread Guide	1		
14- 1- 7	Thread Eyelet Bushing	1				26	Needle Plate	1		
14- 1- 8	Thread Take-up Supporter	1				27	Screw 4.37	2	100032-004	
14- 1- 9	Stud	1				30- 1	Slide Plate	1		C-30 Slide Plate Assembly 180018-001
14- 1-11	Needle Bearing	2				30- 2	Slide Plate Spring	1	114561-001	
14- 1-12	Wick	1	140430-001			30- 3	Screw 2.38	2	122771-002	
14- 1-13	Pin	1				31	Pulley	1		
14- 1-14	Wick 4 x 4	1	158726-001			32	Screw 5.95	2	013761-410	
14- 1-15	Wick 4 x 4	1	158727-001			33	Screw 8.73	1	148900-001	
14- 2- 1	Needle Bar Crank	1		C-14-2 Thread Take-up Lever Assembly	34	Needle Bar Guide	1	145688-000		
14- 2- 2	Screw 3.57 L	1	145465-001			35	Screw 357-40 x 6	2	062670-612	
14- 2- 3	Cap	1				36- 1	Needle Clamp	1		C-36 Needle Clamp Assembly
14- 2- 4	Needle Bar Crank Rod	1				36- 2	Screw 3.57	1	118521-001	
14- 2- 5	Needle Bar Clamp	1				39	Screw 238-56 x 4	1		
14- 2- 6	Screw 357-40 x 8	1	062670-812							

D. Rotary hook mechanism / Greifervorrichtung
 Mécanisme du crochet rotatif / Mecanismo del cangrejo

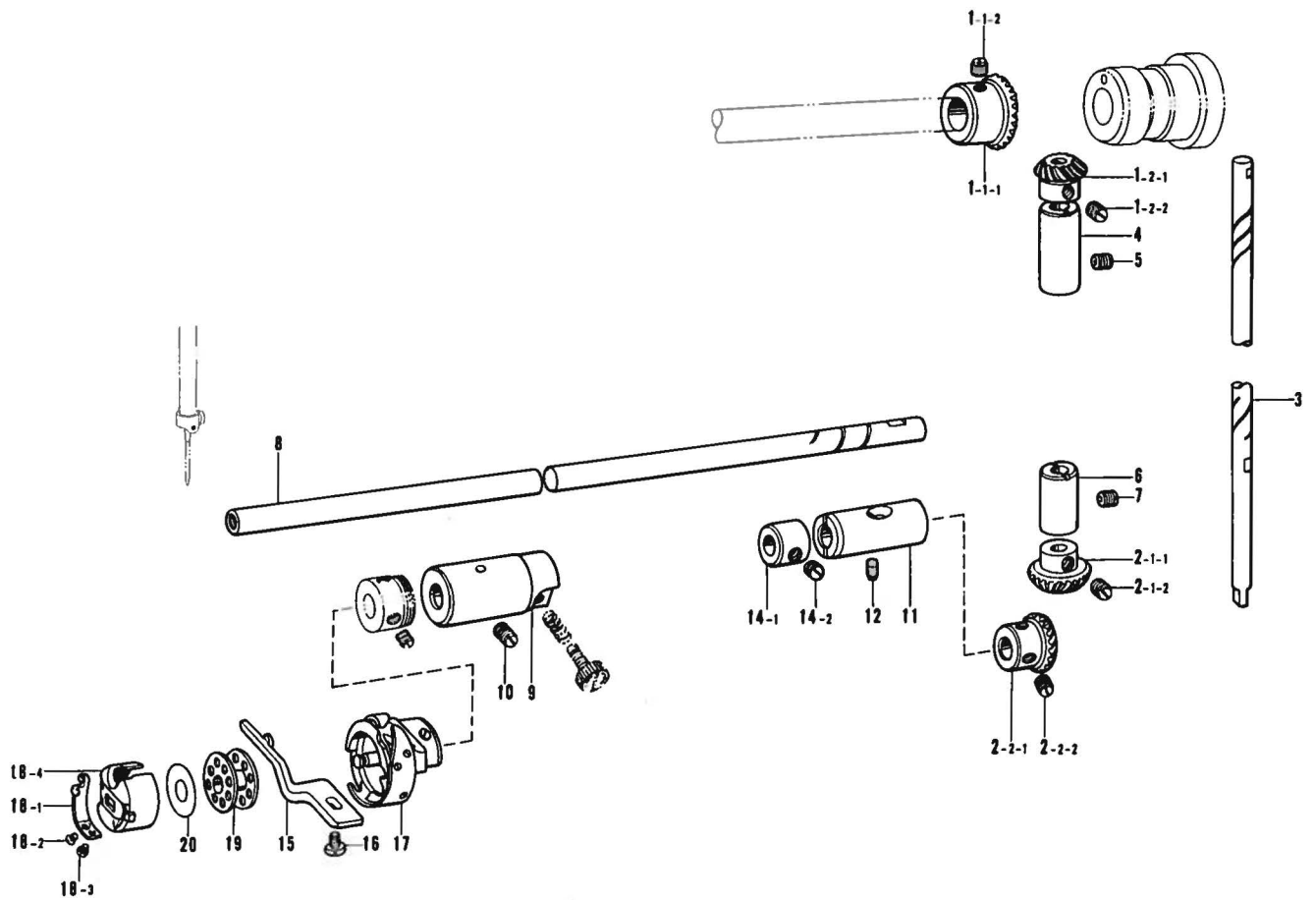

Ref. No.	Name of Parts	Q'ty	Parts No.	Assembly No.	Ref. No.	Name of Parts	Q'ty	Parts No.	Assembly No.
1- 1- 1	Gear	1		D-1 Bevel Gear Upper Assembly 140378-001	10	Screw 4.37	1	125925-002	
1- 1- 2	Screw 6.35	2	100251-001		11	Lower Shaft Bushing Right	1	104520-000	
1- 2- 1	Gear U	1			12	Screw 4.37	1	151607-001	
1- 2- 2	Screw 6.35	2	100251-001		14- 1	Collar	1		D-14 Collar Assembly 181995-001
2- 1- 1	Gear D	1		D-2 Bevel Gear Lower Assembly 140381-001	14- 2	Screw 6.35	2	101706-001	
2- 1- 2	Screw 6.35	2	100251-001		15	Bobbin Case Holder Position Bracket	1	100367-001	
2- 2- 1	Gear	1			16	Screw 4.37	1	107407-003	
2- 2- 2	Screw 6.35	2	100251-001		17	Rotary Hook	1		
3	Vertical Shaft	1	145516-001		18- 1	Lower Thread Adjusting Spring	1	183291-001	D-18 Bobbin Case Assembly 100369-001
4	Vertical Shaft Upper Bushing	1	142708-000	18- 2	Spring Adjusting Screw	1	183292-001		
5	Screw 5.95 x 6	1	013760-610	18- 3	Screw	1	183293-001		
6	Vertical Shaft Lower Bushing	1	142709-000	18- 4	Bobbin Case	1			
7	Screw 5.95	1	013761-410		19	Bobbin	1	117132-001	
8	Lower Shaft	1	109160-001		20	Bobbin Case Sheet	1	140356-001	
9	Lower Shaft Bushing Left	1	118761-000						

E. Feed mechanism (1) / Transportvorrichtung (1)
 Mécanisme de l'entraînement (1) / Mecanismo de la alimentación (1)

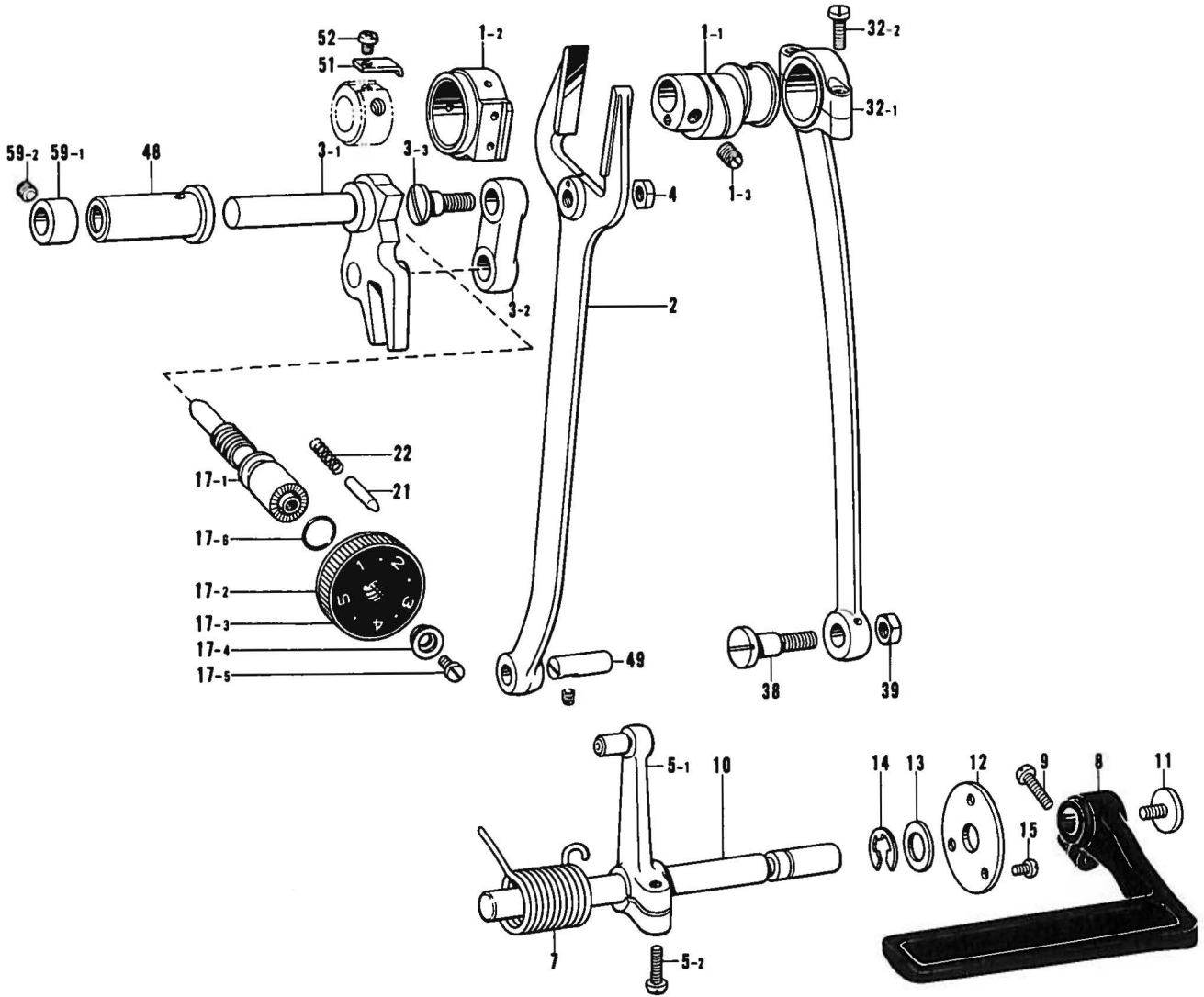

Ref. No.	Name of Parts	Q'ty	Parts No.	Assembly No.	Ref. No.	Name of Parts	Q'ty	Parts No.	Assembly No.
1- 1	Feed Cam	1		E-1 Feed Cam Sleeve Assembly	17- 1	Length Control Screw	1	109151-101	E-17 Length Control Assembly
1- 2	Feed Cam Sleeve	1			17- 2	Length Control Dial	1	153168-001	
1- 3	Screw 5.95	2	151604-001		17- 3	Length Control Plate	1		
2	Feed Forked Connector	1	109147-001	17- 4	Length Control Supporter	1	142746-002		
3- 1	Feed Regulator Assembly	1		17- 5	Screw 4.76	1	142747-002		
3- 2	Feed Link	1	147502-000	E-3 Feed Regulator Assembly	17- 6	O Ring	1	108549-001	
3- 3	Stud Screw 7.14	1	145486-001		21	Pin	1	145502-001	
4	Nut 7.14	1	104689-002		22	Notch Spring	1	100328-001	
5- 1	Lever Assembly	1		E-5 Feed Regulator Lever Assembly 181935-001	32- 1	Crank Rod	1		E-32 Crank Rod Assembly 145506-001
5- 2	Screw 476-32 x 14	1	062711-412		32- 2	Screw 4.76	2	107428-003	
7	Spring	1	150757-001		38	Stud Screw 7.14	1	147509-001	
8	Reverse Lever	1	147503-001	39	Nut 7.14	1	104689-002		
9	Screw 476-32 x 14	1	062711-412	48	Feed Regulator Shaft Bushing	1	147500-000		
10	Reverse Lever Shaft	1	147505-001	49	Feed Rock Shaft Arm Pin	1	109153-001		
11	Screw 4.76	1	100511-003	51	Feed Cam Stopper	1	147764-001		
12	Washer	1	147504-001	52	Screw 357-40 x 4	1	062670-412		
13	Washer 10	1	025100-132	59- 1	Collar	1		E-59 Collar Assembly 183178-001	
14	Stop Ring E8	1	048080-342	59- 2	Screw 6.35	1	123006-001		
15	Screw 357-40 x 5	3	062670-516						

E. Feed mechanism (2) / Transportvorrichtung (2)
 Mécanisme de l'entraînement (2) / Mecanismo de la alimentación (2)

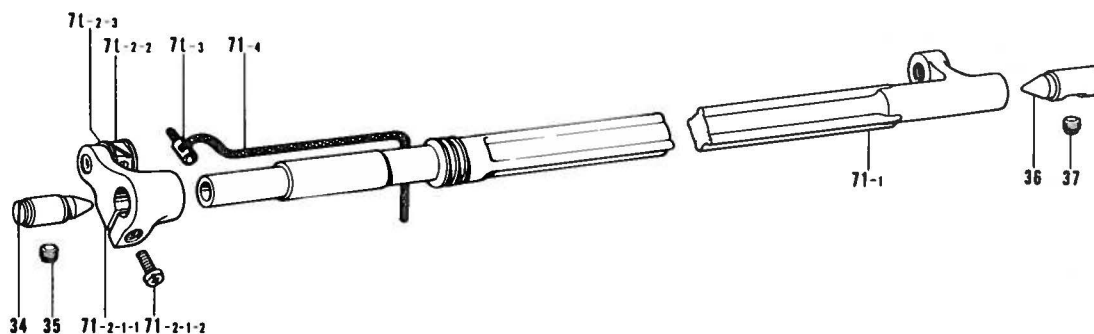
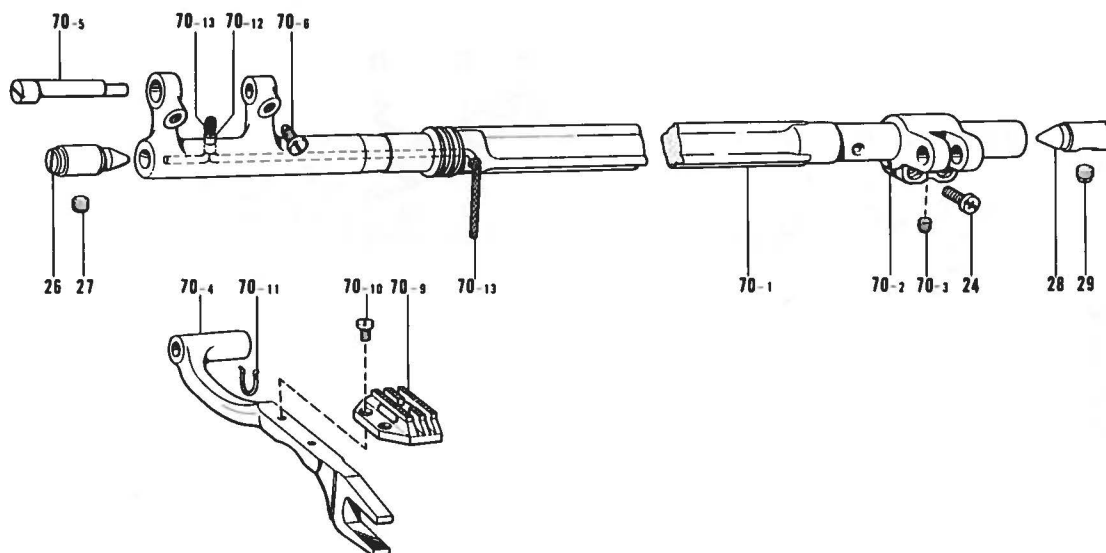

Ref. No.	Name of Parts	Q'ty	Parts No.	Assembly No.	Ref. No.	Name of Parts	Q'ty	Parts No.	Assembly No.
24	Screw 437-40 x 12	2	062681-212		70- 6	Screw 4.37	2	120990-001	
26	Taper Center Left	1	104847-001		70- 9	Feed Dog	1		
27	Screw 6.35	1	100251-001		70-10	Screw 3.18	2	100080-003	E-70 Feed Rock Shaft Assembly
28	Taper Center Right	1	104848-001		70-11	Wick Hanger	1	150342-001	
29	Screw 6.35	1	100251-001		70-12	Vinyle Tube	1	150340-000	
34	Taper Center Left	1	104847-001		70-13	Wick 4 x 4	1	108801-001	
35	Screw 6.35	1	100251-001		71- 1	Feed Lifting Shaft	1	147510-001	
36	Taper Center Right	1	104848-001		71- 2- 1- 1	UD Feed Lifting Arm	1		E-71-2 Feed Lifting Arm Assembly 181941-001
37	Screw 6.35	1	100251-001		71- 2- 1- 2	Screw 437-40 x 16	1	062681-612	
70- 1	Feed Rock Shaft	1	159283-001	E-70 Feed Rock Shaft Assembly	71- 2- 2	Slide Block Assembly	1		E-71 Feed Lifting Shaft Assembly 183117-001
70- 2	Feed Rock Shaft Arm	1	109152-001		71- 2- 3	Washer	1		
70- 3	Screw 4.37	1	151601-002		71- 3	Wick Supporter	1	104567-001	
70- 4	Feed Bar	1	147767-001		71- 4	Wick 4 x 4	1	108802-001	
70- 5	Feed Bar Shaft	1	156246-001						

F. Presser foot mechanism / Stoffdrückerfuß
 Mécanisme du pied presseur / Mecanismo del prensa telas

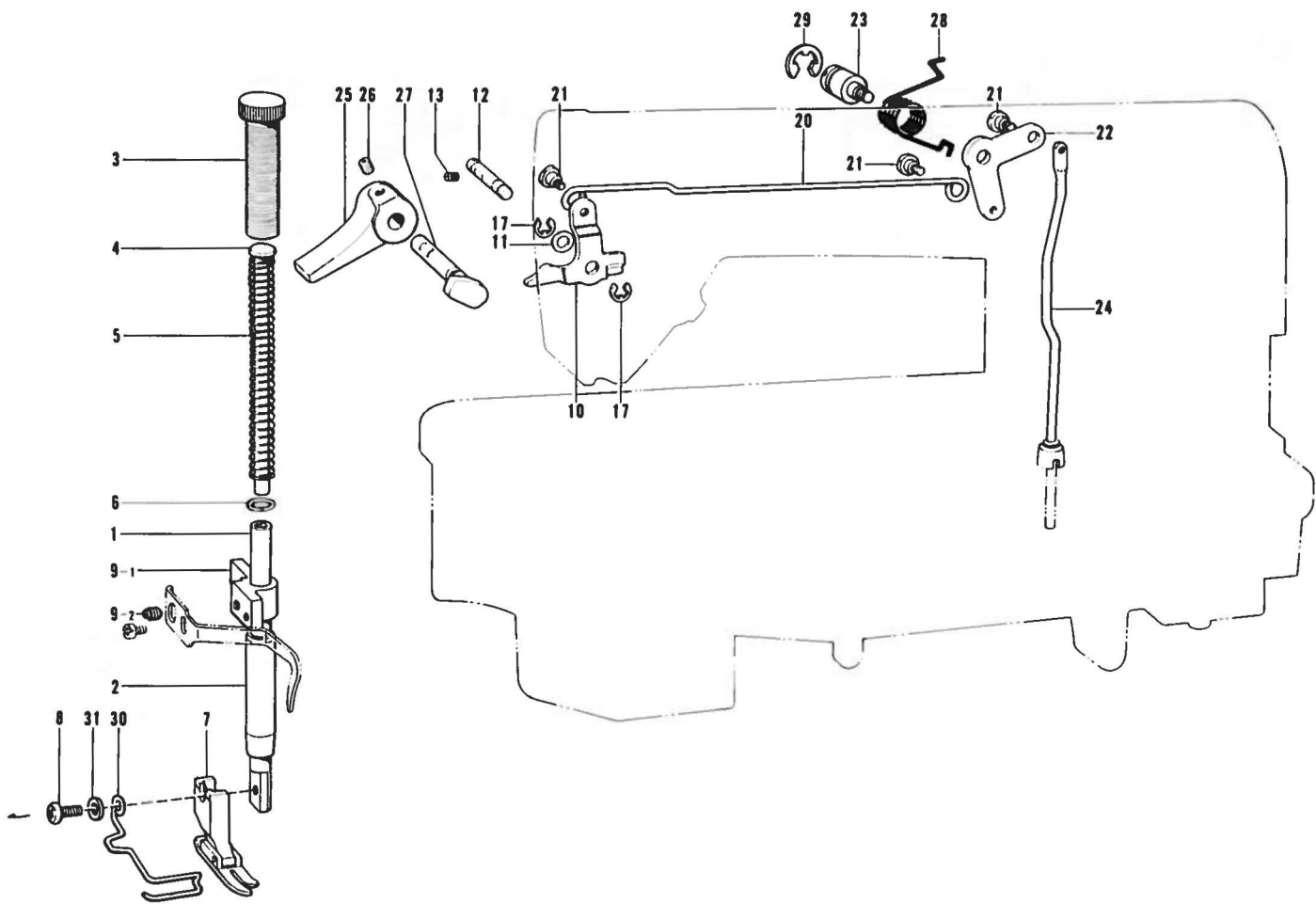

Ref. No.	Name of Parts	Q'ty	Parts No.	Assembly No.	Ref. No.	Name of Parts	Q'ty	Parts No.	Assembly No.
1	Presser Bar	1	111466-001		17	Stop Ring E4	2	048040-342	
2	Presser Bar Bushing	1	145472-001		20	Knee Lifter Connector	1	145476-001	
3	Presser Adjusting Screw	1	141207-001		21	Stud Screw 4.76	3	145478-001	
4	Presser Spring Bar	1	141208-001		22	Knee Lifter Lever	1	145479-001	
5	Presser Spring	1	147514-001		23	Stud 6.35	1	154348-001	
7	Presser Foot Assembly	1			24	Knee Lifter Bar	1	145481-001	
8	Screw 357-40 x 10	1	060671-012		25	Presser Bar Lifter	1	145482-001	
9- 1	Presser Bar Clamp	1		F-9 Presser Bar Clamp Assembly 183294-001	26	Screw 4.76	1	014710-522	
9- 2	Screw 5.95	1	151604-001		27	Presser Bar Lifter Crank	1	145483-001	
10	Presser Bar Lifter Lever	1	S01020-001		28	Spring	1	154347-001	
11	Washer	1	109763-002		29	Stop Ring E8	1	048080-342	
12	Presser Bar Lifter Shaft	1	159998-001		30	Finger Guard	1		
13	Screw 3.57	1	S01998-001		31	Washer 3.5	1		

G. Knee lifter mechanism / Kniehebel
 Mécanisme de genouillère / Mecanismo de levantador de rodilla

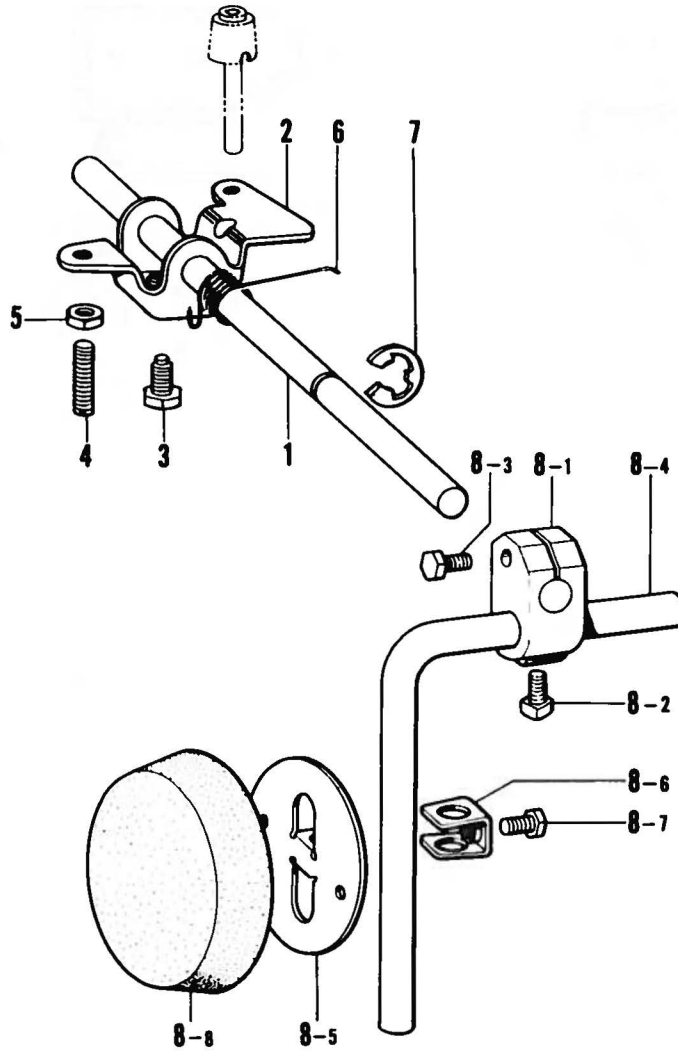

Ref. No.	Name of Parts	Q'ty	Parts No.	Assembly No.	Ref. No.	Name of Parts	Q'ty	Parts No.	Assembly No.
1	Knee Lifter Shaft	1	146036-101		8- 2	Bolt 7.94	1	100463-001	G-8 Knee Lifter Assembly 181427-001
2	Knee Lifter	1	146037-001		8- 3	Bolt 5.95 x 20	1	017762-013	
3	Bolt 5.95	1	146367-001		8- 4	Knee Lifter Bar	1	104619-002	
4	Screw 5.95	2	104885-001		8- 5	Knee Lifter Plate	1	114966-001	
5	Nut 5.95	2	100022-004		8- 6	Knee Lifter Plate Stopper	1	114967-001	
6	Spring	1	146038-001		8- 7	Bolt 5.95	1	110087-001	
7	Stop Ring E10	1	146293-001		8- 8	Knee Lifter Cover	1	140503-001	
8- 1	Knee Lifter Joint	1	146039-001	G-8					

H. Lubrication / Schmierung
Lubrication / Lubricación

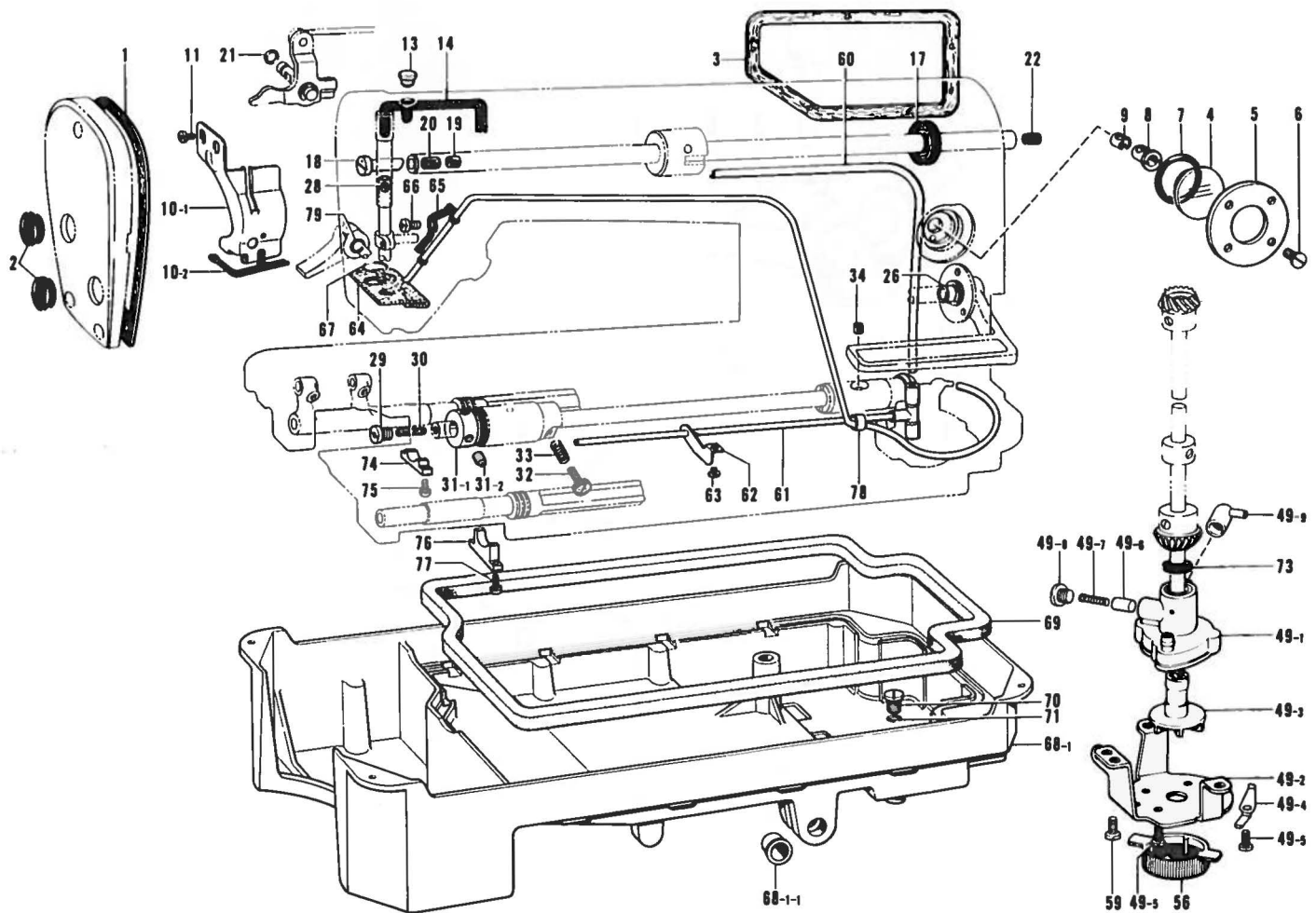

Ref. No.	Name of Parts	Q'ty	Parts No.	Assembly No.	Ref. No.	Name of Parts	Q'ty	Parts No.	Assembly No.
1	Packing	1	145527-000		49- 1	Pump Body	1	148848-001	H-49 Pump Body Assembly 181476-201
2	Oil Cap	2	104449-001		49- 2	Pump	1	144869-002	
3	Packing	1	145528-000		49- 3	Pump Propeller	1	148849-001	
4	Oil Gauge Window	1	104547-001		49- 4	Spring	2	144874-001	
5	Oil Gauge Flange	1	151074-001		49- 5	Screw 357-40 x 8	4	062670-812	
6	Screw 357-40 x 6	4	062670-612		49- 6	Plunger	1	144875-001	
7	O Ring PW14	1	081014-670		49- 7	Spring	1	144876-001	
8	Tube Holder	1	145529-000		49- 8	Oil Draining Screw 6.35	1	112467-002	
9	Tube Holder Cap	1	146314-000		49- 9	Joint B	1	144878-001	
10- 1	Oil Stopper Plate	1	145530-001	H-10 Oil Stopper Plate Assembly 181639-001	56	Pump Filter	1	144872-001	
10- 2	Wick 4 x 4	1	109405-001		59	Screw 437-40 x 7	3	062680-712	
11	Screw 357-40 x 5	2	062670-512		60	Oil Tube Upper	1	147496-000	
13	Oil Cap	1	111865-001		61	Oil Tube D Assembly	1	145540-001	
14	Wick 4 x 4	1	108804-001		62	Tube Holder	1	145981-001	
17	Oil Seal	1	101487-000		63	Screw 437-40 x 6	1	062680-612	
18	Oil Adjustor	1	146333-001		64	Tube Assembly	1	145543-001	
19	Felt 7 x 10	1	146327-001		65	Tube Holder	1	145547-001	
20	Felt	1	107149-001		66	Screw 357-40 x 5	1	062670-516	
21	O Ring PW1	1	081001-670		67	Felt Support	1	145737-001	
22	Oil Cap	1	156641-001		68- 1	Oil Pan	1	149580-001	
26	O Ring	1	104564-001		68- 1- 1	Bushing	2	149578-000	
28	Needle Bar Cork	1			69	Packing	1	146040-001	
29	Screw	1	109173-001		70	Screw 7.94	1	140518-001	
30	Felt	1	106436-001		71	O Ring P7	1	081007-070	
31- 1	Oil Rejector	1		H-31 Oil Rejector Assembly 144943-001	73	Oil Stopper	1	146196-001	
31- 2	Screw 4.37	2	151602-002		74	Oil Stopper	1	118558-001	
32	Screw	1	145534-001		75	Screw 357-40 x 8	2	062670-812	
33	Spring	1	116794-001		76	Oil Stopper	1	118559-001	
34	Felt	1	107155-001		77	Screw 357-40 x 8	2	062670-812	
					78	Tube	1	146253-000	
					79	O Ring PW1	1	081001-670	

J. Bobbin winder mechanism / Spuler
 Mécanisme du bobineur / Mecanismo del de vanador la canilla

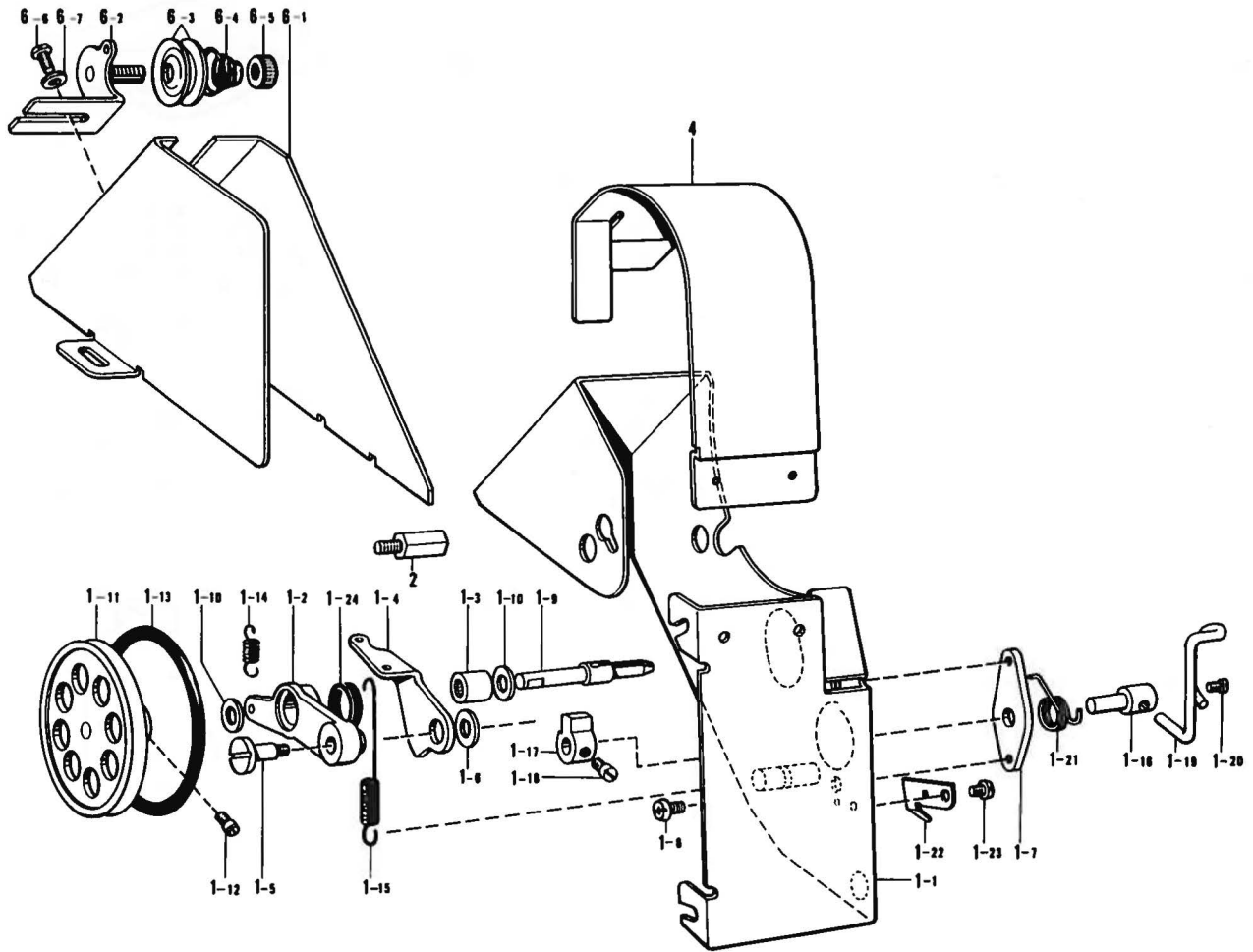

Ref. No.	Name of Parts	Q'ty	Parts No.	Assembly No.	Ref. No.	Name of Parts	Q'ty	Parts No.	Assembly No.
1- 1	Belt Cover	1		J-1 Belt Cover Assembly	1-18	Screw 4.37 x 5	2	100366-002	J-1 Belt Cover Assembly
1- 2	Bobbin Winder Arm	1	157956-001		1-19	Bobbin Presser	1	157966-001	
1- 3	Needle Bearing	1	147568-001		1-20	Screw 4.37 x 5	1	100366-002	
1- 4	Bobbin Winder Cam Lever	1	157957-001		1-21	Spring	1	157967-001	
1- 5	Stud Screw 4.37	1	157958-001		1-22	Knife	1	157968-001	
1- 6	Washer	1	157986-001		1-23	Screw 437-40 x 5	1	062680-512	
1- 7	Bobbin Winder Bracket	1	157959-001		1-24	Seal	1	103738-001	
1- 8	Screw 437-40 x 5	1	062680-512		2	Stud	1		
1- 9	Bobbin Winder Shaft	1	157960-001		4	Belt Cover U	1		
1-10	Washer	2	118735-002		6- 1	Belt Cover D	1	157971-001	J-6 Belt Cover D Assembly
1-11	Bobbin Winder	1	157961-000		6- 2	Bobbin Winder Guide Bracket Assembly	1	145571-101	
1-12	Screw 3.57	2	801998-001		6- 3	Tension Disc	2	145446-001	
1-13	O Ring P62	1	081062-090		6- 4	Tension Spring	1	100401-001	
1-14	Spring	1	157962-001		6- 5	Tension Control Nut	1	100136-001	
1-15	Cam Lever Spring	1	157963-001		6- 6	Screw 357-40 x 6	1	060670-612	
1-16	Cam Shaft	1	157964-001		6- 7	Washer 3.5	1	025350-332	
1-17	Bobbin Winder Claw	1	142566-001						

Z. Accessories (I) / Zubehör (I) / Accessoires (I) / Accesorios (I)

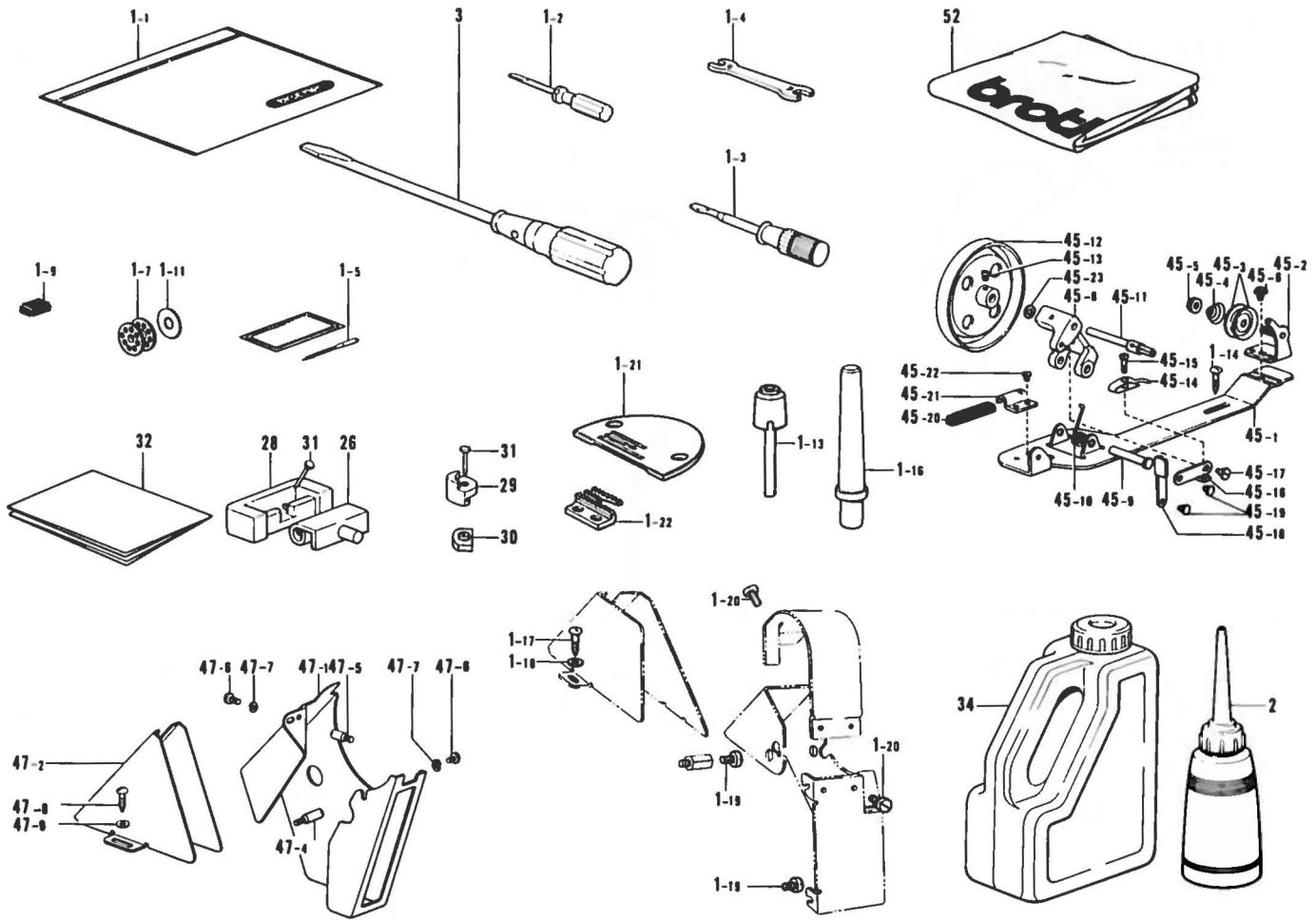

Ref. No.	Name of Parts	Q'ty	Parts No.	Assembly No.	Ref. No.	Name of Parts	Q'ty	Parts No.	Assembly No.
1- 1	Vinyl Bag	1	122991-001		45- 3	Tension Disc	2	145446-001	
1- 2	Screw Driver 1.9 x 52	1	142443-001		45- 4	Tension Spring	1	100401-001	
1- 3	Screw Driver 3.4 x 70	1	118837-001		45- 5	Nut	1		
1- 4	Spanner 8 x 9	1	100887-001		45- 6	Screw 437-40 x 6	1		
1- 5	Needle				45- 8	Bobbin Winder Wheel Shaft Supporter	1		
1- 7	Bobbin	4	117132-001		45- 9	Pin	1		
1- 9	Magnet	2	112525-000		45-10	Spring	1	117969-001	
1-11	Bobbin Case Sheet	2	140356-001		45-11	Bobbin Winder Shaft	1	117970-001	
1-13	Knee Lifter Complying Bar	1	145573-000	Z-1 Parts Assembly	45-12	Bobbin Winder Wheel Assembly	1		Z-45 Bobbin Winder Assembly
1-14	Screw 5.5 x 20	2			45-13	Screw 4.37 x 5	1	100366-002	
1-16	Head Rest	1	100477-001		45-14	Bobbin Presser	1		
1-17	Screw 5.5 x 20	2			45-15	Screw 318-40 x 14	1	062661-412	
1-18	Washer 5.56	2			45-16	Bobbin Presser Arm	1		
1-19	Screw 595-28 x 8	3			45-17	Stud Screw 3.18	1	100659-001	
1-20	Screw 357-40 x 6	3			45-18	Bobbin Presser Arm Bracket	1		
1-21	Needle Plate	1			45-19	Pin	2	100661-001	
1-22	Feed Dog	1			45-20	Bobbin Winder Wheel Stopper	1	100662-001	
2	Oiler Assembly	1			45-21	Bobbin Winder Wheel Stopper Holder	1		
3	Screw Driver 5.5 x 190	1			45-22	Screw 3.57 x 3.5	1	S01297-001	
26	Hinge Assembly	2	143882-001		45-23	Washer	2		
28	Rubber Cushion	2	143910-001		47- 1	Belt Cover UE	1		
29	Head Cushion	4	146003-101		47- 2	Belt Cover D	1		
30	Oil Pan Cushion	4	146004-001		47- 4	Stud (A)	1	147855-001	
31	Nail	8	109714-000		47- 5	Stud (B)	1	147856-001	Z-47 Belt Cover Assembly E
32	Table Sheet	1	144615-001		47- 6	Screw 437-40 x 8	2	062680-812	
34	Oil Tank	1	154702-001		47- 7	Spring Washer 2-4.37	2	028680-242	
45- 1	Bobbin Winder Wheel Bracket	1		Z-45 Bobbin Winder Assembly	47- 8	Screw 5.5 x 20	2	100666-002	
45- 2	Bobbin Winder Wheel Guide Bracket Assembly	1			47- 9	Washer 5.56	2	025750-132	
					52	Head Cover	1		

* The details of included accessories are subject to change.

* Änderungen in der Aufstellung der mitgelieferten Zubehöre sind vorbehalten.

* Les détails des accessoires inclus sont sujets à des changements.

* Los detalles de los accesorios incluidos pueden variar.

Z. Accessories (2) / Zubehör (2) Accessoires (2) / Accesorios (2)

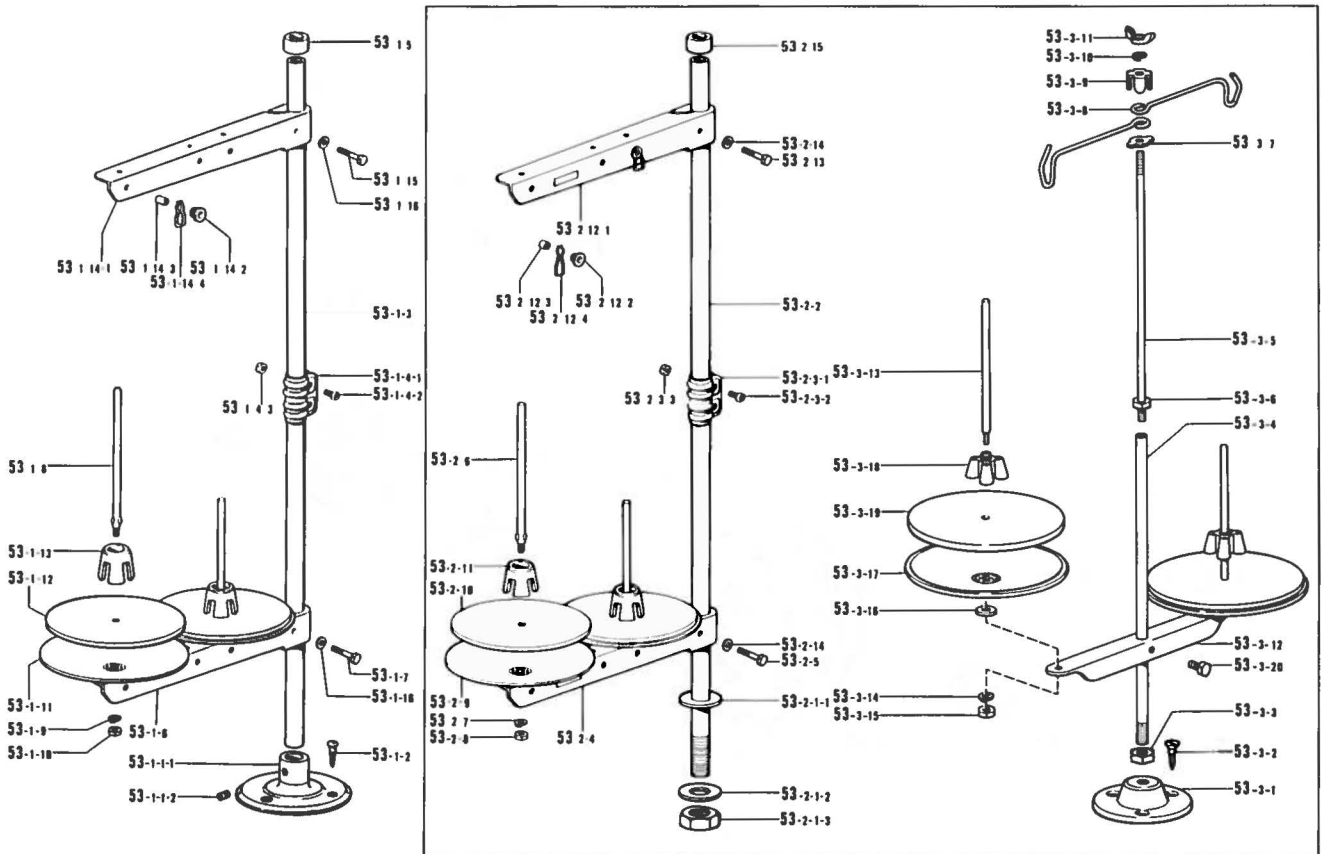

Ref. No.	Name of Parts	Q'ty	Parts No.	Assembly No.	Ref. No.	Name of Parts	Q'ty	Parts No.	Assembly No.
53-1-1-1	Cotton Stand Base	1	150189-001	Z-53-1-1 Cotton Stand Base Assembly 150139-001	53-2-7	Spring Washer 2-5	2	028050-243	Z-53-2 Thread Stand Assembly 2D
53-1-1-2	Screw 6 x 7	2	150181-101		53-2-8	Nut 5	2	021500-103	
53-1-2	Screw 4.5 x 22	3	031452-203		53-2-9	Spool Stand Base	2	150180-000	
53-1-3	Pipe	2	150172-001		53-2-10	Spool Mat	2	150182-000	
53-1-4-1	Joint	1		Z-53-1-4 Joint for Cotton Stand Assembly 150106-001	53-2-11	Spool Cushion	2	126863-000	
53-1-4-2	Screw 5 x 14	2	150202-001		53-2-12-1	Spool Holder 2	1	150178-001	Z-53-2-12 Thread Hanger Assembly 2 150192-003
53-1-4-3	Nut 5	2	021500-103		53-2-12-2	Thread Hanger	2		
53-1-5	Cap	1			53-2-12-3	Thread Bushing	2	142990-001	
53-1-6	Spool Holder 2	1	150178-001		53-2-12-4	Thread Guide Spring	2	150184-001	
53-1-7	Bolt 5 x 28	1	017502-803		53-2-13	Bolt 5 x 28	1	017502-803	
53-1-8	Spool Shaft (B)	1	150179-001	Z-53-1 Cotton Stand Assembly 2	53-2-14	Washer 5	2	025050-233	
53-1-9	Spring Washer 2-5	2	028050-243		53-2-15	Cap	1		
53-1-10	Nut 5	2	021500-103		53-3-1	Bracket	1		
53-1-11	Spool Stand Base	2	150180-000		53-3-2	Screw 4.5 x 22	2	033452-203	
53-1-12	Spool Mat	2	150182-000		53-3-3	Nut 9	1	140917-001	
53-1-13	Spool Cushion	2	126863-000		53-3-4	Lower Column	1		
53-1-14-1	Spool Holder 2	1	150178-001		53-3-5	Upper Column	1		
53-1-14-2	Thread Hanger	2		Z-53-1-14 Thread Hanger Assembly 2 150192-003	53-3-6	Nut 6	1	140921-001	
53-1-14-3	Thread Bushing	2	142990-001		53-3-7	Spring	1		
53-1-14-4	Thread Guide Spring	2	150184-001		53-3-8	Thread Hanger	1		
53-1-15	Bolt 5 x 28	1	017502-803		53-3-9	Stopper	1		
53-1-16	Washer 5	2	025050-233		53-3-10	Spring Washer 2-6	1	028060-242	Z-53-3 Cotton Stand Assembly
53-2-1-1	Pipe D	1		Z-53-2-1 Pipe D Assembly 156111-001	53-3-11	Nut 6	1		
53-2-1-2	Washer 16	1	150206-001		53-3-12	Spool Holder	1		
53-2-1-3	Nut U 5/8	1	150191-001		53-3-13	Spool Shaft	2		
53-2-2	Pipe	1	150172-001		53-3-14	Spring Washer 2-5	2	028050-242	
53-2-3-1	Joint	1		Z-53-2-3 Joint for Cotton Stand Assembly 150106-001	53-3-15	Nut 5	2	140918-001	
53-2-3-2	Screw 5 x 14	2	150202-001		53-3-16	Washer 5	2	025050-233	
53-2-3-3	Nut 5	2	021500-103		53-3-17	Spool Stand Base	2		
53-2-4	Spool Holder 2	1	150178-001		53-3-18	Spring	2		
53-2-5	Bolt 5 x 28	1	017502-803	Z-53-2 Thread Stand Assembly 2D	53-3-19	Spool Mat	2		
53-2-6	Spool Shaft (B)	2	150179-001		53-3-20	Bolt 5.95	1	110087-001	

* The details of included accessories are subject to change.
 * Änderungen in der Aufstellung der mitgelieferten Zubehöre sind vorbehalten.

* Les détails des accessoires inclus sont sujets à des changements.
 * Los detalles de los accesorios incluidos pueden variar.

a. Option parts / Sonderzubehör / Pièces en option / Piezas opciona

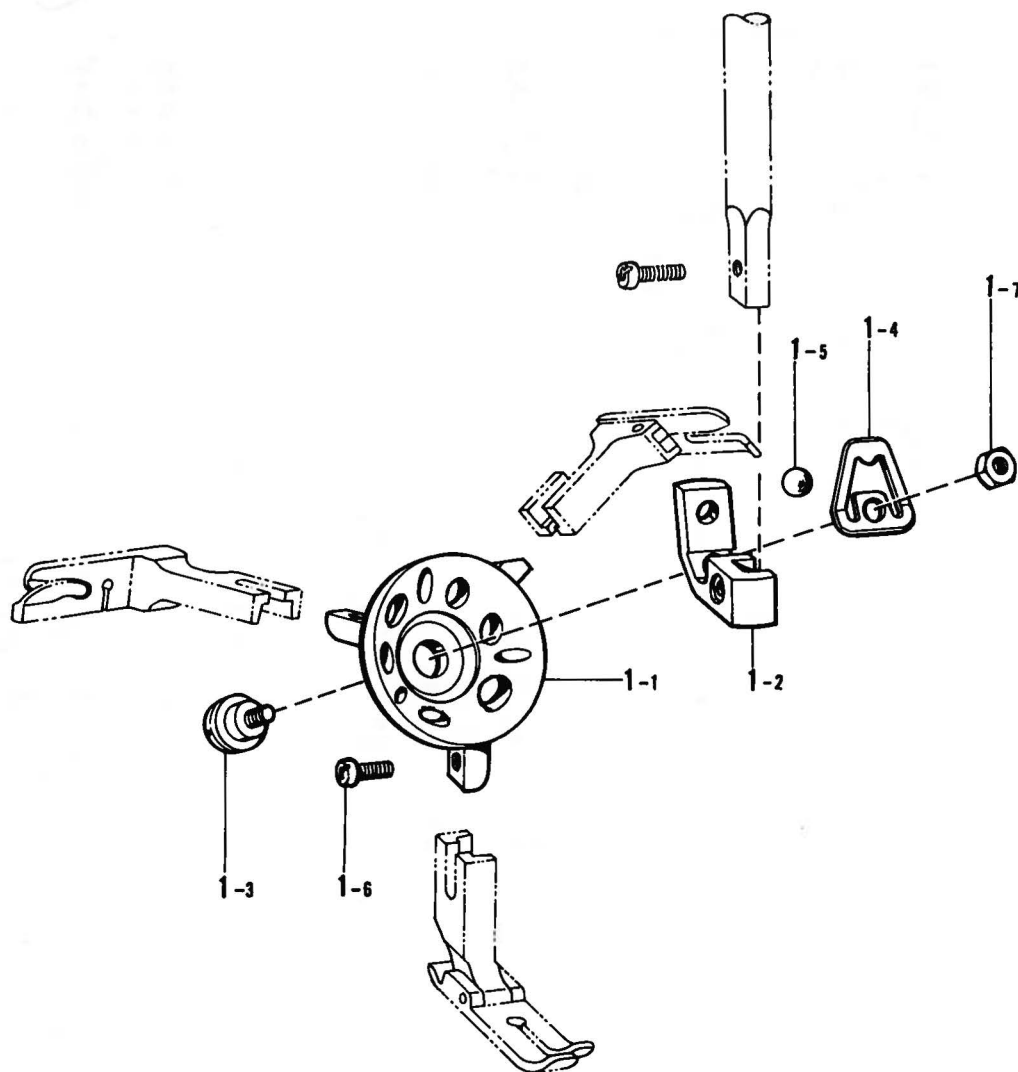

Ref. No.	Name of Parts	Q'ty	Parts No.	Assembly No.	Ref. No.	Name of Parts	Q'ty	Parts No.	Assembly No.
1- 1	Presser Body	1	154629-001	a-1 Turret Presser Assembly 154628-001	1- 5	Steel Ball	1	154633-000	a-1 Turret Presser Assembly 154628-001
1- 2	Presser Foot Arm	1	154630-001		1- 6	Screw 357-40 x 8	3	060670-812	
1- 3	Stud Screw 4.37	1	154631-001		1- 7	Nut 4.37	1	105234-003	
1- 4	Plate Spring	1	154632-001						

GAUGE PARTS LIST/LEHREN LISTE
 LISTE DES PIECES DECARTEMENT/LISTA DE PIEZAS CALIBRADORAS

Feed Dog	Needle Plate	Presser Foot Assembly	
S00868-001 S01108-001	S00867-001 S01107-001 S01126-001 S01127-001	113280-001 140957-001 147531-001 153037-101	
S01235-001	S01515-001	113280-001 140957-001 147531-001	
100334-001	100266-001	113280-001	140957-001
	100267-001		
	111241-001		
	145971-001		
	146050-001		140957-001
	146232-001		
	147238-001		
	147239-001 153190-001		140957-001
111860-001 147143-001	111859-001 156114-001 156115-001 156116-001	113280-001 140957-001 147531-001	
111898-001	100602-001 100603-001 117216-001 146053-001	111856-001 143711-001	
117442-001	141096-001	113280-001 140957-001	
144500-001	100267-001	113280-001	145157-001
	111241-001		
	145971-001		
	147245-001		
	147322-001		145157-001
144500-001 154742-001	111508-001	113280-001 145157-001	
146231-001	146232-001	113280-001	
	146233-001		140957-001
150793-001	150792-001	150789-001	
159858-001	159859-001	113280-001 140957-001 147531-001	

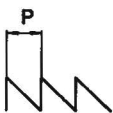
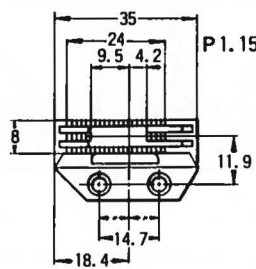
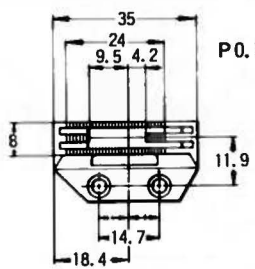
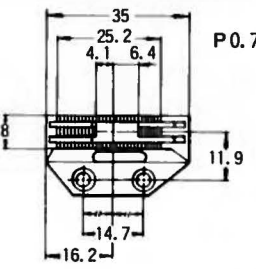
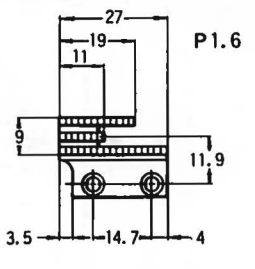
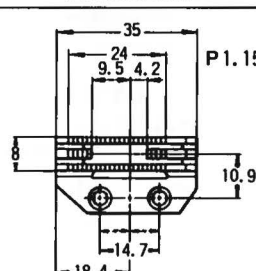
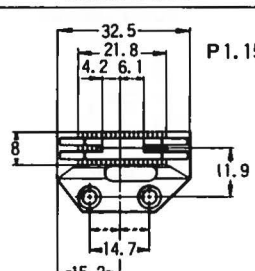
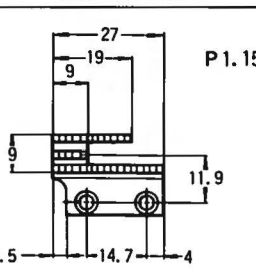
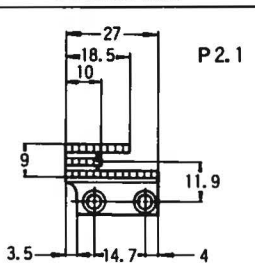
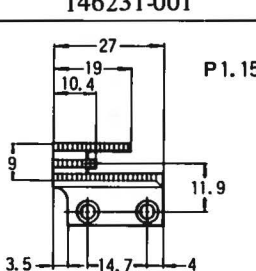
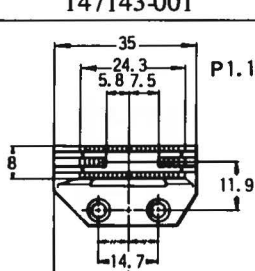
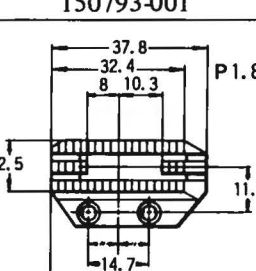
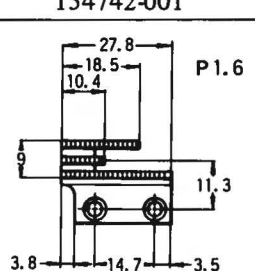
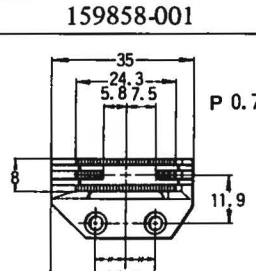
<p>Feed Dog</p> 	<p>S00868-001</p> 	<p>S01108-001</p> 	<p>S01235-001</p> 	<p>100334-001</p> 
	<p>111860-001</p> 	<p>111898-001</p> 	<p>117442-001</p> 	<p>144500-001</p> 
	<p>146231-001</p> 	<p>147143-001</p> 	<p>150793-001</p> 	<p>154742-001</p> 
	<p>159858-001</p> 			

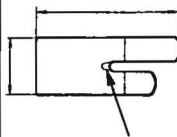
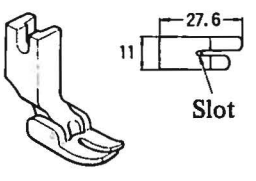
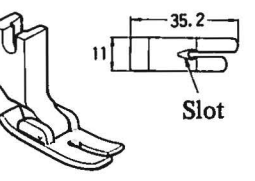
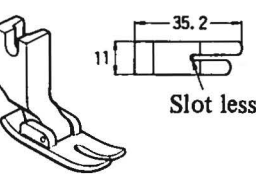
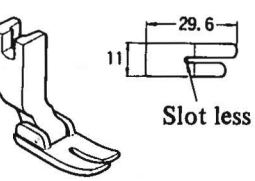
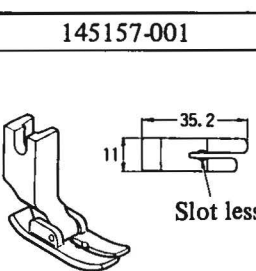
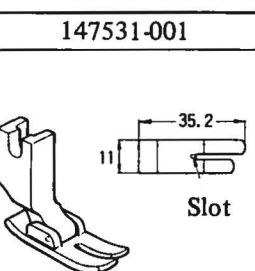
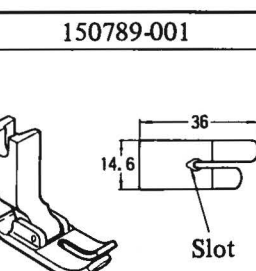
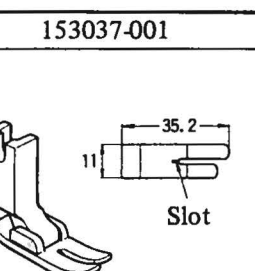
<p>Presser Foot Assembly</p> 	<p>111856-001</p> 	<p>113280-001</p> 	<p>140957-001</p> 	<p>143711-001</p> 
	<p>145157-001</p> 	<p>147531-001</p> 	<p>150789-001</p> 	<p>153037-001</p> 

	<p>S00867-001</p> <p>Medium</p>	<p>S01107-001</p> <p>Thin</p>	<p>S01126-001</p> <p>Thin</p>	<p>S01127-001</p> <p>Medium</p>
	<p>S01515-001</p> <p>Medium</p>	<p>10266-001</p> <p>Medium</p>	<p>100267-001</p> <p>Thick</p>	<p>100602-001</p> <p>Medium</p>
	<p>100603-001</p> <p>Thin</p>	<p>111241-001</p> <p>Thick</p>	<p>111508-001</p> <p>Thick</p>	<p>111859-001</p> <p>Medium</p>
<p>Needle Plate</p>	<p>117216-001</p> <p>Thin</p>	<p>141096-001</p> <p>Medium</p>	<p>145971-001</p> <p>Medium</p>	<p>146050-001</p> <p>Thin</p>
	<p>146053-001</p> <p>Thin</p>	<p>146232-001</p> <p>Medium</p>	<p>146233-001</p> <p>Thin</p>	<p>147238-001</p> <p>Thin</p>
	<p>147239-001</p> <p>Medium</p>	<p>147245-001</p> <p>Thick</p>	<p>147322-001</p> <p>Thick</p>	<p>150792-001</p> <p>Thin</p>

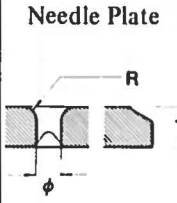
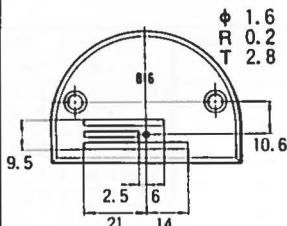
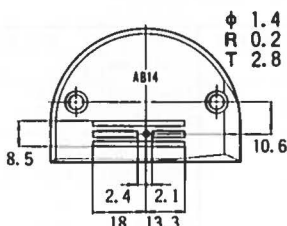
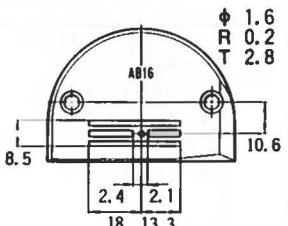
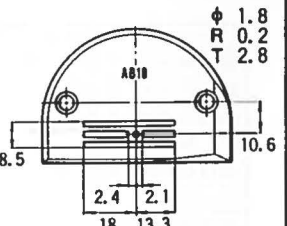
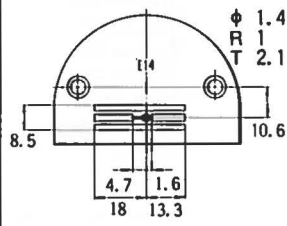
 <p>Needle Plate</p>	<p>153190-001</p>  <p>Thin</p>	<p>156114-001</p>  <p>Thin</p>	<p>156115-001</p>  <p>Medium</p>	<p>156116-001</p>  <p>Medium</p>	
	<p>159859-001</p>  <p>Thin</p>				

INDEX / VERZEICHNIS
INDEX / INDICE

Parts No.	Ref. No.	Remark	Parts No.	Ref. No.	Remark	Parts No.	Ref. No.	Remark	Parts No.	Ref. No.	Remark
S01020-001	F-10		062680-712	H-59		104450-001	A-13		112467-002	H-49- 8	
S01107-001	C-26		062680-812	Z-47- 6		104451-001	A-24		112525-000	Z- 1- 9	
S01108-001	E-70- 9		062681-212	E-24		104464-001	C-11		113280-001	F- 7	
S01126-001	Z- 1-21		062681-612	E-71- 2- 1- 2		104520-000	D-11		114294-001	B-35- 9	
S01235-001	E-70- 9		062711-412	E- 5- 2		104525-001	B-35- 7		114483-002	Z- 2	
S01297-001	Z-45-22			E- 9		104547-001	H- 4		114561-001	C-30- 2	
S01426-001	Z- 1		062760-812	Z- 1-19		104564-001	H-26		114908-001	C-21	
S01515-001	C-26		081001-670	H-21		104567-001	E-71- 3		114931-001	B-10	
S01998-001	F-13			H-79		104619-002	G- 8- 4		114966-001	G- 8- 5	
	J- 1-12		081007-070	H-71		104689-002	E- 4		114967-001	G- 8- 6	
013760-610	C- 5		081014-670	H- 7			E-39		115244-001	C-31	
	C- 7		081062-090	J- 1-13		104821-001	A-19		116780-001	D-17	
	D- 5		100022-004	G- 5		104829-101	A- 4		116794-001	H-33	
013761-410	C-32		100032-004	C-27		104830-101	A- 5		116922-001	B-35- 2	
	D- 7		100080-003	E-70-10		104832-001	A-18		117132-001	D-19	
013781-012	C-15		100090-004	A- 7		104833-001	A-22			Z- 1- 7	
014710-522	F-26		100136-001	B-35- 8		104847-001	E-26		117963-001	Z-45	
017502-803	Z-53- 1- 7			J- 6- 5			E-34		117969-001	Z-45-10	
	Z-53- 1-15		100251-001	C- 8- 2		104848-001	E-28		117970-001	Z-45-11	
	Z-53- 2- 5			C-10- 2			E-36		118521-001	C-36- 2	
	Z-53- 2-13			D- 1- 1- 2		104885-001	G- 4		118558-001	H-74	
017762-013	G- 8- 3			D- 1- 2- 2		105234-003	a- 1- 7		118559-001	H-76	
021500-103	Z-53- 1-4- 3			D- 2- 1- 2		106436-001	H-30		118735-002	J- 1-10	
	Z-53- 1-10			D- 2- 2- 2		107149-001	H-20		118761-000	D- 9	
	Z-53- 2- 3- 3			E-27		107155-001	H-34		118768-001	C-14- 2-11	
	Z-53- 2- 8			E-29		107407-003	D-16		118832-000	H-28	
025050-233	Z-53- 1-16			E-35		107415-011	C-22		118837-001	Z- 1- 3	
	Z-53- 2-14			E-37			Z- 1- 5		120990-001	E-70- 6	
	Z-53- 3-16		100260-001	C-20		107415-014	C-22		122771-002	C-30- 3	
025100-132	E-13		100265-031	C-22			Z- 1- 5		122991-001	Z- 1- 1	
025350-132	F-31			Z- 1- 5		107415-018	C-22		123006-001	E-59- 2	
025350-332	J- 6- 7		100265-034	C-22			Z- 1- 5		125925-002	D-10	
025750-132	Z- 1-18			Z- 1- 5		107415-022	C-22		126863-000	Z-53- 1-13	
	Z-47- 9		100265-042	C-22			Z- 1- 5			Z-53- 2-11	
028050-242	Z-53- 3-14			Z- 1- 5		107428-003	E-32- 2		140356-001	D-20	
028050-243	Z-53- 1- 9		100266-001	C-26		108520-001	A-23			Z- 1-11	
	Z-53- 2- 7		100267-001	C-26		108549-001	E-17- 6		140378-001	D- 1	
028060-242	Z-53- 3-10			Z- 1-21		108801-001	E-70-13		140381-001	D- 2	
028680-242	Z-47- 7		100328-001	E-22		108802-001	E-71- 4		140430-001	C-14- 1-12	
031452-203	Z-53- 1- 2		100334-001	E-70- 9		108804-001	H-14		140503-001	G- 8- 8	
033452-203	Z-53- 3- 2		100366-002	J- 1-18		108960-002	B-33		140518-001	H-70	
048040-342	F-17			J- 1-20		109143-001	C-17		140553-102	C-23	
048080-342	E-14			Z-45-13		109147-001	E- 2		140726-000	C- 4	
	F-29		100367-001	D-15		109151-101	E-17- 1		140885-005	B-27	
060670-612	J- 6- 6		100369-001	D-18		109152-001	E-70- 2		140917-001	Z-53- 3- 3	
060670-812	a- 1- 6		100398-001	B-35- 2		109153-001	E-49		140918-001	Z-53- 3-15	
060671-012	F- 8		100400-000	B-20		109160-001	D- 8		140921-001	Z-53- 3- 6	
062630-412	C-39		100401-001	J- 6- 4		109173-001	H-29		141207-001	F- 3	
062661-412	Z-45-15			Z-45- 4		109206-001	C-19		141208-001	F- 4	
062670-412	E-52		100402-004	B-35- 3		109356-001	C-21		142116-001	C-19	
062670-512	H-11		100463-001	G- 8- 2		109405-001	H-10- 2		142443-001	Z- 1- 2	
062670-516	E-15		100477-001	Z- 1-16		109714-000	Z-31		142566-001	J- 1-17	
	H-66		100511-003	E-11		109763-002	F-11		142708-000	D- 4	
062670-612	B-26		100573-001	B-34		110087-001	G- 8- 7		142709-000	D- 6	
	C-35		100659-001	Z-45-17			Z-53- 3-20		142746-002	E-17- 4	
	H- 6		100661-001	Z-45-19		110367-001	C-16		142747-002	E-17- 5	
	Z- 1-20		100662-001	Z-45-20		111234-101	C-14- 1		142990-001	Z-53- 1-14- 3	
062670-812	A-10		100666-002	Z- 1-14		111275-001	D-17			Z-53- 2-12- 3	
	C-14- 1- 5			Z- 1-17		111462-001	C-21		143882-001	Z-26	
	C-14- 2- 6			Z-47- 8		111463-001	C-17		143910-001	Z-28	
	H-49- 5		100887-001	Z- 1- 4		111465-000	C-10- 1		143930-001	C-36	
	H-75		101487-000	H-17		111466-001	F- 1		144222-001	Z-52	
	H-77		101572-101	Z- 3		111469-101	B-23		144500-001	E-70- 9	
062671-012	B-31		101706-001	D-14- 2		111476-001	B-32			Z- 1-22	
062672-012	B-30		102630-001	C-24		111508-001	C-26		144502-001	B- 1	
062680-512	J- 1- 8		102716-004	B- 1- 5		111856-001	F- 7		144504-001	B- 1- 3	
	J- 1-23		103738-001	J- 1-24		111859-001	C-26		144505-000	B- 1- 4	
062680-612	H-63		103950-003	B-21		111860-001	E-70- 9		144577-001	C-25- 3	
062680-712	B-24		104449-001	A-11		111863-001	H-28		144615-001	Z-32	
	B-28			H- 2		111865-001	H-13		144741-001	B-35- 1	

Parts No.	Ref. No.	Remark	Parts No.	Ref. No.	Remark	Parts No.	Ref. No.	Remark	Parts No.	Ref. No.	Remark
144869-002	H-49- 2		147504-001	E-12		154629-001	a- 1- 1		183203-001	E-70	
144872-001	H-56		147505-001	E-10		154630-001	a- 1- 2		183204-001	E-70	
144874-001	H-49- 4		147509-001	E-38		154631-001	a- 1- 3		183226-001	J- 6	
144875-001	H-49- 6		147510-001	E-71- 1		154632-001	a- 1- 4		183282-001	E-70	
144876-001	H-49- 7		147511-001	C- 1		154633-000	a- 1- 5		183291-001	D-18- 1	
144878-001	H-49- 9		147514-001	F- 5		154702-001	Z-34		183292-001	D-18- 2	
144943-001	H-31		147551-101	C-14- 2		154737-001	Z- 1		183293-001	D-18- 3	
145153-001	B-35- 7		147568-001	J- 1- 3		154766-000	C-10- 1		183294-001	F- 9	
145157-001	F- 7		147573-001	E- 1		154792-001	E-17- 3		183311-001	E-70	
145446-001	B-35- 5		147764-001	E-51		156111-001	Z-53- 2- 1				
	J- 6- 3		147767-001	E-70- 4		156126-001	C-14- 2				
	Z-45- 3		147855-001	Z-47- 4		156145-101	Z- 1				
145454-001	A- 6		147856-001	Z-47- 5		156201-001	B-35				
145455-002	A- 8		147899-011	Z-47		156246-001	E-70- 5				
145459-101	C- 2		148848-001	H-49- 1		156634-001	E- 3				
145461-101	C- 6		148849-001	H-49- 3		156636-001	E- 3				
145465-001	C-14- 1- 2		148900-001	C-33		156641-001	H-22				
	C-14- 2- 2		148965-000	C-10- 1		156795-101	Z-53- 3				
145468-001	C-19		149313-101	C-14- 2		156968-001	C-10				
145471-001	C-31		149578-000	H-68- 1- 1		157089-001	F- 7				
145472-001	F- 2		149580-001	H-68- 1		157953-001	J- 1				
145476-001	F-20		150106-001	Z-53- 1- 4		157956-001	J- 1- 2				
145478-001	F-21			Z-53- 2- 3		157957-001	J- 1- 4				
145479-001	F-22		150125-001	Z-53- 2		157958-001	J- 1- 5				
145481-001	F-24		150139-001	Z-53- 1- 1		157959-001	J- 1- 7				
145482-001	F-25		150150-003	Z-53- 1		157960-001	J- 1- 9				
145483-001	F-27		150172-001	Z-53- 1- 3		157961-000	J- 1-11				
145486-001	E- 3- 3			Z-53- 2- 2		157962-001	J- 1-14				
145502-001	E-21		150178-001	Z-53- 1- 6		157963-001	J- 1-15				
145506-001	E-32			Z-53- 1-14- 1		157964-001	J- 1-16				
145516-001	D- 3			Z-53- 2- 4		157966-001	J- 1-19				
145519-001	B-35- 4			Z-53- 2-12- 1		157967-001	J- 1-21				
145520-001	B-35- 7		150179-001	Z-53- 1- 8		157968-001	J- 1-22				
145522-001	B-25			Z-53- 2- 6		157969-001	J- 2				
145523-102	B-29		150180-000	Z-53- 1-11		157970-001	J- 4				
145526-001	B-22			Z-53- 2- 9		157971-001	J- 6- 1				
145527-000	H- 1		150181-101	Z-53- 1- 1- 2		157986-001	J- 1- 6				
145528-000	H- 3		150182-000	Z-53- 1-12		158726-001	C-14- 1-14				
145529-000	H- 8			Z-53- 2-10			C-14- 2-11				
145530-001	H-10- 1		150184-001	Z-53- 1-14- 4		158727-001	C-14- 1-15				
145534-001	H-32			Z-53- 2-12- 4			C-14- 2-12				
145540-001	H-61		150189-001	Z-53- 1- 1- 1		159283-001	E-70- 1				
145543-001	H-64		150191-001	Z-53- 2- 1- 3		159471-001	C-10				
145547-001	H-65		150192-003	Z-53- 1-14		159474-001	C-10				
145571-101	J- 6- 2			Z-53- 2-12		159805-001	B-35- 6				
145573-000	Z- 1-13		150202-001	Z-53- 1- 4- 2		159936-001	Z- 1				
145624-000	C-14- 2-10			Z-53- 2- 3- 2		159990-001	Z- 1				
145688-000	C-34		150206-001	Z-53- 2- 1- 2		159998-001	F-12				
145737-001	H-67		150340-000	E-70-12		180018-001	C-30				
145981-001	H-62		150342-001	E-70-11		181427-001	G- 8				
145986-001	C-21		150384-001	F-30		181476-201	H-49				
146003-101	Z-29		150757-001	E- 7		181482-101	E-17				
146004-001	Z-30		150792-001	C-26		181634-001	B-35				
146036-101	G- 1		150793-001	E-70- 9		181635-001	B-35				
146037-001	G- 2		151063-001	E- 1		181639-001	H-10				
146038-001	G- 6		151074-001	H- 5		181916-001	C- 8				
146039-001	G- 8- 1		151507-001	E-17- 3		181935-001	E- 5				
146040-001	H-69		151594-001	C-25		181941-001	E-71- 2				
146196-001	H-73		151601-002	E-70- 3		181995-001	D-14				
146253-000	H-78		151602-002	B-11		183058-001	E- 1				
146293-001	G- 7			H-31- 2		183117-001	E-71				
146314-000	H- 9		151604-001	E- 1- 3		183121-001	Z- 1				
146327-001	H-19			F- 9- 2		183122-001	Z- 1				
146333-001	H-18		151607-001	D-12		183130-001	Z- 1				
146367-001	G- 3		153037-101	F- 7		183175-001	B-35				
147322-001	C-26		153058-001	E- 1		183178-001	E-59				
147496-000	H-60		153168-001	E-17- 2		183189-001	Z- 1				
147500-000	E-48		154347-001	F-28		183192-001	Z- 1				
147502-000	E- 3- 2		154348-001	F-23		183196-001	E-70				
147503-001	E- 8		154628-001	a- 1		183197-001	E-70				



117-714
195714-102
1984. 7